

Clarke®

PUMP



CPE WATER PUMP

MODEL NO: CPE30A1

PART NO: 7120315

OPERATION & MAINTENANCE INSTRUCTIONS



ORIGINAL INSTRUCTIONS

GC1120

INTRODUCTION

Thank you for purchasing this Clarke Water Pump.

Your CPE pump is a highly efficient, robust, continuously rated, self priming pump with a powerful electric motor, and is ideal for a wide range of domestic, commercial and agricultural uses. It is suitable for pumping clean tap and rain water, and will handle small solids in suspension. It is designed to give you trouble free service provided it is installed and used in the correct way. If the pump is left in an exposed position, it should be protected from the elements. especially frost.

Before attempting to use this product, please read this manual thoroughly and follow the instructions carefully. In doing so you will ensure the safety of yourself and that of others around you, and you can look forward to your purchase giving you long and satisfactory service.

This water pump has been designed to give long and trouble free service. If, however, having followed the instructions in this booklet carefully, you encounter problems, take the unit to your local Clarke dealer.

Please keep these instructions in a safe place for future reference.

PUMP SPECIFICATION

Motor size	3 HP
Water Classification	Clean
Maximum Delivery	800 L/min
Maximum Rated Head	18 m
Supply	230V / 50Hz
Outlet Thread Size	3" BSP
Weight	15.5 kg

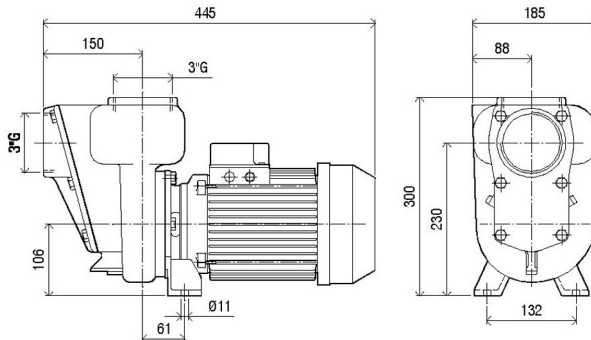
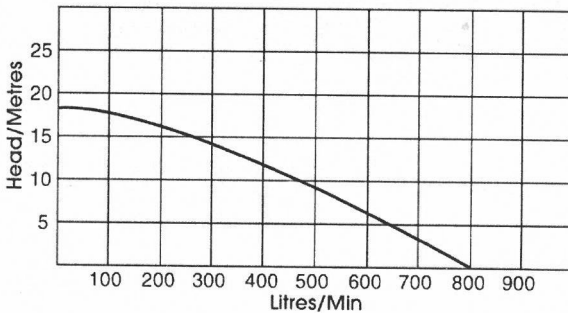

GENERAL SAFETY PRECAUTIONS

Before using this equipment it is in your own interest to read and pay attention to the following safety rules.



WARNING: ALWAYS CONNECT THE PUMP TO AN EARTHED POWER SUPPLY VIA AN RCD.

1. **NEVER** use for pumping flammable liquids or corrosive chemicals. This pump is designed to pump clean water only.
 2. **ALWAYS** keep the working area clean and well lit. Floors should always be kept clear. Cluttered or dark areas invite accidents.
 3. **NEVER** over-reach. Keep your proper footing and balance at all times when installing or maintaining the pump.
 4. **NEVER** direct any water discharge towards electrical wiring or equipment.
 5. **ALWAYS** thoroughly familiarise yourself with this pump & its operation, and follow all instructions in this manual. Never allow persons unfamiliar with these instructions to instal or operate the pump.
 6. **ALWAYS** ensure that the pump is properly installed to prevent it from moving during operation, and that the immediate area surrounding the pump is kept clear.
 7. **ALWAYS** maintain the pump with care and keep it clean for best / safest performance.
 8. **NEVER** use this product if any part is damaged. Have it inspected and repaired by your local Clarke dealer. Always turn the pump off before carrying out any maintenance.
 9. **NEVER** modify this pump in any way. Use it ONLY for the purpose for which it is designed.
 10. **ALWAYS** have the pump serviced by your local Clarke dealer, using only identical replacement parts. This will ensure the safety of the pump is maintained. The use of non standard parts could be hazardous.
 11. **NEVER** allow the pump to run dry.
-



CAUTION: THIS PUMP IS NOT A SUBMERSIBLE PUMP. ON NO ACCOUNT SHOULD IT EVER BE IMMERSIED IN WATER.

INSTALLATION

Because of the number of possible installations, no accessories are supplied with your pump except for a pair of male inlet/outlet adaptors. However accessories are available from your nearest Clarke dealer.

NOTE: It is recommended that the end user should consult a qualified installer if there are any doubts as to the suitability of this product for a particular installation.

IMPORTANT: The pump MUST NOT be connected to the mains power supply until all hose/pipe installation is completed. and it has been primed.

POSITIONING OF THE PUMP

The pump must always be installed and operated in a horizontal position i.e. with the outlet port facing vertically upwards. The fixing holes in the base should be used to secure the pump firmly in it's operating position. Mount the pump on raised blocks or a purpose built platform to protect it from flooding. Some kind of anti-vibration mounting is also desirable.

Always ensure there is adequate air circulation around the motor. The pump should be installed in a dry, well ventilated enclosure, sheltered from rain.

ELECTRICAL CONNECTION

The pump should be located at such a distance away from any pond or pool, as to avoid the possibility of immersion and the power supply should also be a safe distance away. If in doubt, please contact your electrical specialist and refer to national regulations.

Avoid situations where the pump could become drenched with water as neither the motor or terminal box are designed to be totally waterproof. Ensure the pump & its power cable do not create a safety hazard for people walking past it.

ELECTRICAL CONNECTIONS



WARNING! READ THESE ELECTRICAL SAFETY INSTRUCTIONS THOROUGHLY BEFORE CONNECTING THE PRODUCT TO THE MAINS SUPPLY.

Before switching the pump on, make sure that the voltage of your electricity supply is the same as that indicated on the rating plate or on the junction box cover on top of the motor. This product is designed to operate on 230VAC 50Hz. Connecting it to any other power source may cause damage.

Installation should be carried out by a qualified electrician, using I.E.E approved cable and fittings, and in accordance with I.E.E. Regulations. However, in the further interests of safety we would emphasise the electrical hazard

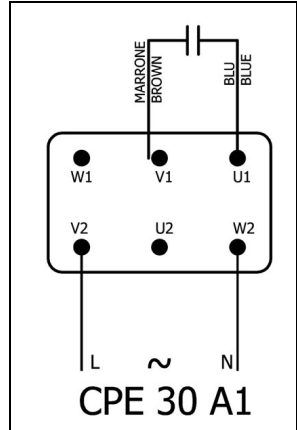

WARNING: WIRES IN THE MAINS LEAD ARE COLOURED IN ACCORDANCE WITH THE FOLLOWING CODE: GREEN/YELLOW = EARTH, BLUE = NEUTRAL, BROWN = LIVE.

- The BLUE wire must be connected to the terminal marked N or coloured black.
- The BROWN wire must be connected to the terminal marked L or coloured red.
- The YELLOW AND GREEN wire must be connected to the terminal marked E or \perp or coloured green.

Plug must be BS1363/A approved.

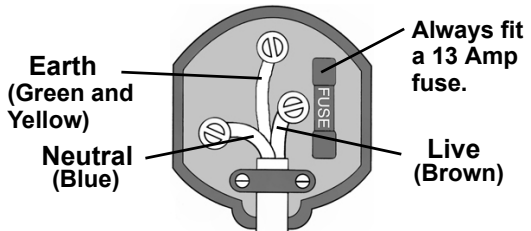

Ensure that the outer sheath of the cable is firmly held by the clamp

We strongly recommend that this machine is connected to the mains supply via a Residual Current Device (RCD).

If in any doubt, consult a qualified electrician. DO NOT attempt any connections yourself.

PIPE/HOSE CONNECTIONS

The pump inlet and discharge ports are both 1½" BSP (38 mm) female threads and accept the adaptors supplied.

Hoses with the same diameter should be used and secured to the adaptor with a suitable hose clip.

Ensure all connections are air tight when under pressure but not so tight as to crack the plastic inlet/outlet adaptors.

These notes are for guidance on how to achieve a proper working system. The diagram (Fig. 1) above shows a typical installation at the pump.

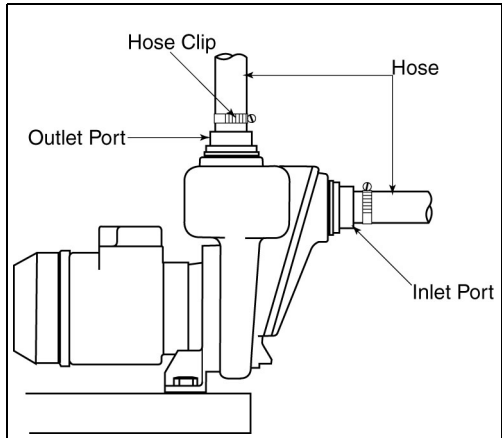

A foot valve and filter should be fitted to the lower end of the suction hose, as illustrated in Fig. 2, so as to retain water in the suction system and more importantly, to prevent the possibility of large foreign objects entering the pump body.

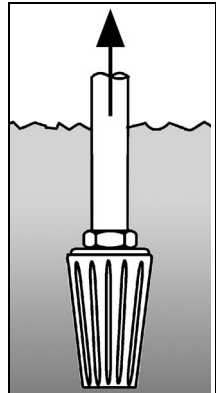

FURTHER CONSIDERATIONS

- Strain caused by vibration can be reduced by connecting a short flexible hose between any rigid pipework and the pump.
- We recommend that you always use pipes/hoses with a minimum diameter of 1½" (38 mm).
- Any restriction in the pipeline will greatly reduce the flow.
- Ensure that the hoses and pipes are supported along their entire length. They will be considerably heavier when filled with water.
- We recommend that you install isolation valves either side of the pump in order to isolate the pump during maintenance/removal.
- A gate valve may be installed in-line on the delivery side of the pump which can be adjusted as required to regulate the flow of water and can assist in priming the pump.

- **WARNING:**-DO NOT place any such obstruction on the suction side (inlet Port) of the pump unless it is an isolator valve in a gravity fed system. It is also IMPORTANT to note, that these pumps should not be operated with the delivery valve completely closed.
- If there is any chance of freezing, protect the pump and pipework with suitable lagging. The formation of ice may cause serious damage.

IMPORTANT: The pump MUST NOT be connected to the mains supply until all hose/pipe installation is completed. DO NOT RUN THE PUMP DRY

NOTE: If any part of the system is to be connected to the mains water supply ensure that local water authority regulations are observed.

OPERATION

1. Open any valves in the pipeline.
2. If operating the pump for the first time, prime the pump as described.

NOTE: Re-priming) is only necessary if the pump has been drained.

3. Connect to the power supply and switch on.
 - When water starts to flow through the system check for leaks and correct as necessary.
 - If the motor fails to start or the pump does not deliver water, refer to TROUBLESHOOTING.
 - Never operate the pump when not primed with water or if the inlet is blocked which would allow the pump to run dry, causing damage.

NOTE: Filling the suction pipe with water will speed up the priming process, and it is essential that a non-return valve be fitted to the end of the suction pipe.

4. Stop the pump by switching off the power supply.

CARE DURING USE

1. Do not allow the pump to run dry otherwise the seal between the pump and motor may be damaged. If a leak occurs at this point, allowing water to pass from the pump to the motor, take the pump to your Clarke dealer for overhaul.
2. In the event of a blockage, where debris has entered the pump, it can be cleaned out as described under MAINTENANCE.
3. DO NOT USE for pumping chemicals or other corrosive liquids. Should contaminants enter the pump, flush through with water as soon as possible to prevent damage.
4. If the pump is being used to drain a pool, ensure there is adequate drainage and there is no risk of damage to property as a result of water being discharged. If a flexible hose must be laid across a roadway, protect it with wooden planking.

MAINTENANCE

Inspect the pump/hoses regularly to ensure that debris is not blocking the passage of water. If you suspect the pump is blocked by silt, leaf debris etc, disconnect it from the power supply, disconnect the discharge hose and back-flush to clear any blockage using a hosepipe.

Always keep the pump in a clean condition and check regularly for damage to the power cable etc.

All electrical connections should be inspected regularly for signs of corrosion and cleaned where necessary. It is advisable to apply a film of silicon grease on the terminals for added protection.

AFTER USE

After use, and if the pump will not be used over the winter period or if there is danger of freezing, always drain the pump body.

If the pump has been used with contaminated or salty water it should be thoroughly flushed with clean water following use, both inside and out. It should then be drained and covered over if not already sheltered from the weather.

If the pump is seized following a period of inactivity it may be possible to free it off. Ensure the power supply is turned off before by inserting a screwdriver into either the infeed or discharge port and dislodging a jammed impeller. If this is not successful it may be necessary to remove the relevant mounting bolts to separate the pump body and clean away any incrustation.

Re-prime the pump when returning to service.

In the event that overhaul of the pump or motor is necessary, contact your Clarke service department.

ENVIRONMENTAL RECYCLING POLICY



Through purchase of this product, the customer is taking on the obligation to deal with the WEEE in accordance with the WEEE regulations in relation to the treatment, recycling & recovery and environmentally sound disposal of the WEEE.

In effect, this means that this product must not be disposed of with general household waste. It must be disposed of according to the laws governing Waste Electrical and Electronic Equipment (WEEE) at a recognised disposal facility.

TROUBLESHOOTING

Problem	Cause	Solution
Pump does not run.	Thermal protection has been activated.	If the motor has overheated, wait for it to cool down before trying again.
	Faulty power connection	Check and repair connection as necessary.
	No mains supply	Check fused power supply and replace fuse if necessary (check fuse rating). Check circuit breaker
	Impeller seized/blocked	Disconnect pump from power supply. Investigate cause and clear blockage
Pump fails to prime	Air leaks through suction hose joints (damaged hose, broken clamp, damaged).	Repair connections/ replace hose as necessary.
	Blocked inlet hose	Check pipeline for blockage. Check any inlet valve fitted is fully open.
Pump runs but gives poor output	Congested material inside pump	Clean out & backflush pump.
	Suction or delivery line obstructed.	Remove obstruction and ensure there are no kinks in delivery line.
	Inlet pipe leakage.	Check inlet pipe and connector for leaks. Tighten as required.
	Air leaks through damaged seal.	Renew seal.
	Impeller damaged and making poor seal.	Return to your Clarke dealer for repair
	Impeller / mechanical seal is badly worn.	Return to your Clarke dealer for repair.

	High friction losses in the suction line.	Avoid unnecessary curves, restrictions or valves
	Pump badly sited resulting in suction lift too high	Set pump as close as possible to the level of the water to be pumped
Sudden loss of flow.	Blockage of inlet pipe	Check pipeline for blockage.
Undue vibration or noise.	Excessive flow of water.	Decrease flow of water. by adjusting inlet/outlet valves in system.
	Resistance in inlet pipe caused by obstruction.	Check pipe and clean out as necessary
	Loose rotating component	Return to your dealer for repairs.
	Installation of pump is unstable.	Stop pump and re-position.
	Air pocket in pump or pipeline.	Release plug in impeller housing to release air.
	Damaged impeller	Return to your Clarke dealer for repair.

GUARANTEE

This product is guaranteed against faulty manufacture for a period of 12 months from the date of purchase. Please keep your receipt which will be required as proof of purchase.

This guarantee is invalid if the product is found to have been abused or tampered with in any way, or not used for the purpose for which it was intended.

Faulty goods should be returned to their place of purchase, no product can be returned to us without prior permission.

This guarantee does not effect your statutory rights.

PARTS DIAGRAM - CPE30A

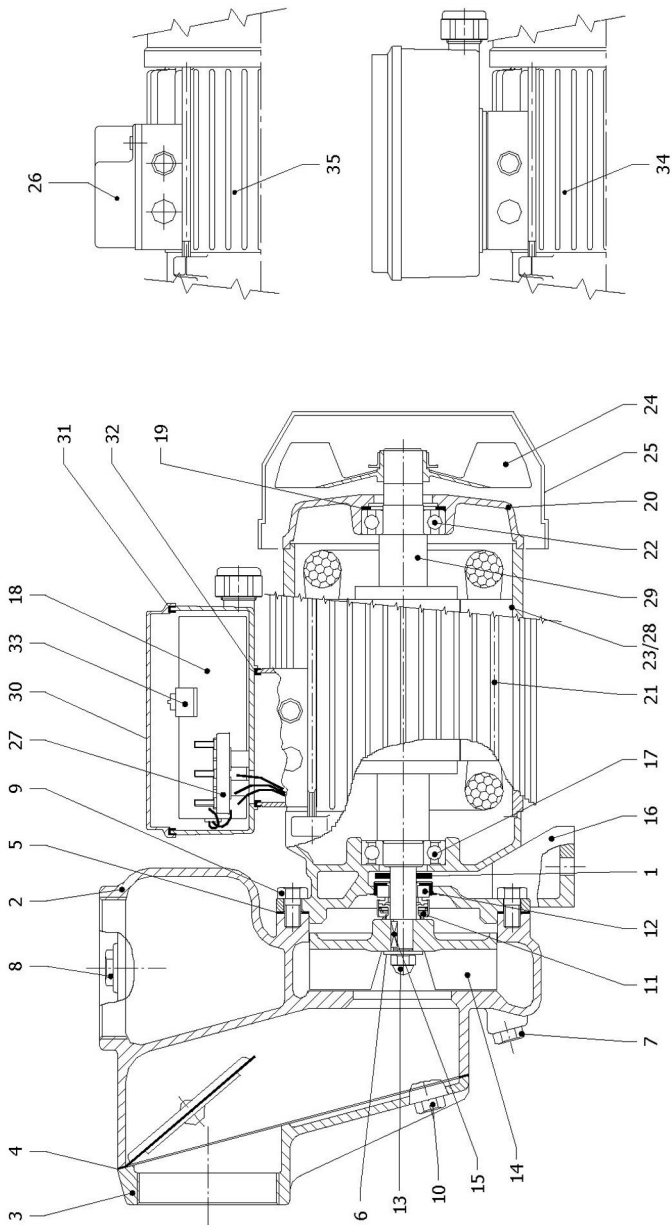

PARTS LIST - CPE30A

ID	DESCRIPTION	MANUFID
1	Washer	GM5342
2	Pump body	GM5574
3	Valve body	GM5857
4	Check valve	GM613
5	Flexolite gasket	GM6029
6	Washer	GM6162
7	Drain plug	GM6211
8	Plug	GM6230
9	Screw	GM6235
10	Screw	GM6261
11	Mechanical seal	GM6334
12	Counterface	GM6346
13	Nut	GM7103
14	Impeller	GM8613
15	Key 4 x 4 x 16	GMF156
16	Motor bracket	GM5505
17	Bearing	GM6321

ID	DESCRIPTION	MANUFID
18	Condenser	GM6854
19	Elastic washer	GM7187
20	Rear motor cover	GM8010
21	N/a	N/a
22	Bearing	GM8013
23	Motor stator	GM8014
24	Fan	GM8016
25	Fan cover	GM8017
26	Junction box cover	GM8018
27	Junction box	GM8025
28	Motor stator	GM8052
29	Motor shaft	GM8652
30	Condensor box	GM9194
31	Gasket	GML045
32	Gasket	GML046
33	Condenser clip	GM8286
34	Motor	GM8659

ACCESSORIES

1½" BSP Plastic Foot Valve Filter FVF15	Part No:7950682
1½" dia Reinforced Suction/Delivery Hose	Part No:7955015
1½" dia Layflat Delivery Hose 10M	Part No:7955155
1½" BSP Female Coupling	Part No:7950315
1½" BSP Male Coupling	Part No:7950215

DECLARATION OF CONFORMITY



Hemmill Street, Epping, Essex, CM16 4LG

DECLARATION OF CONFORMITY

This is an important document and should be retained.

Product Description:

Model number(s): Water Pump
Serial / batch Number: CPE300A1
Date of Issue: 06/11/2020
(Noise Conformity) -

Notified Body:

-

Technical Documentation Holder:

A.R. Pond
Clarke International
2a Shrubland Road
London E10 7RB
UK

Conformity Assessment Procedure:

Manufacturer: to 2000/14/EC Annex V
Noise Related Value: European Supplier
Measured Sound Power Level: 2.25 kW
Guaranteed Sound Power Level: 68 dB
70 dB

DECLARATION OF CONFORMITY

This is an important document and should be retained.

We hereby declare that this product(s) complies with the following directive(s):

- 2014/30/EU Electromagnetic Compatibility Directive.
- 2006/42/EC Machinery Directive.
- 2014/35/EU Low Voltage Equipment Directive.
- 2011/65/EU Restriction of Hazardous Substances (amended by (EU) 2015/863).
- 2000/14/EC Noise Emissions Directive, (amended by 2005/69/EC).

The following standards have been applied to the product(s):

EN ISO 72100-2010, EN 60971:1998-04:2009, EN 60204-1.

The technical documentation required to demonstrate that the product(s) meet(s) the requirement(s) of the aforementioned directive(s) has been compiled and is available for inspection by the relevant enforcement authorities.

The CE mark was first applied in: 2015

Signed:

J.A. Clarke
Director



Hemmill Street, Epping, Essex, CM16 4LG

A SELECTION FROM THE VAST RANGE OF

Clarke®

QUALITY PRODUCTS



AIR COMPRESSORS

From DIY to industrial, Plus air tools, spray guns and accessories.

GENERATORS

Prime duty or emergency standby for business, home and leisure.

POWER WASHERS

Hot and cold, electric and engine driven - we have what you need

WELDERS

Mig, Arc, Tig and Spot.
From DIY to auto/industrial.

METALWORKING

Drills, grinders and saws for DIY and professional use.

WOODWORKING

Saws, sanders, lathes, mortisers and dust extraction.

HYDRAULICS

Cranes, body repair kits, transmission jacks for all types of workshop use.

WATER PUMPS

Submersible, electric and engine driven for DIY, agriculture and industry.

POWER TOOLS

Angle grinders, cordless drill sets, saws and sanders.

STARTERS/CHARGERS

All sizes for car and commercial use.

PARTS & SERVICE:

0208 988 7400

Parts Enquiries

Parts@clarkeinternational.com

Servicing & Technical Enquiries

Service@clarkeinternational.com

SALES: UK 01992 565333 or Export 00 44 (0)1992 565335

Clarke INTERNATIONAL Hemnall Street, Epping, Essex CM16 4LG
www.clarkeinternational.com